

BIFURCATED FAN SECTION

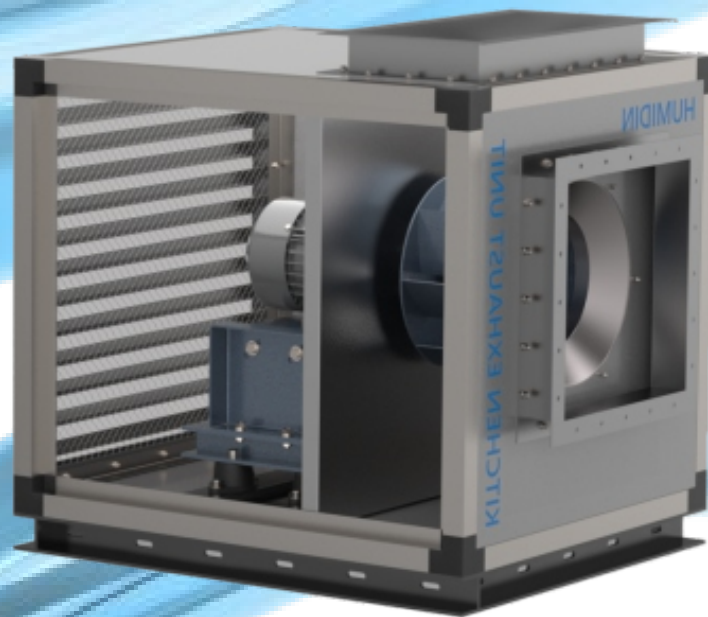

Quality Speaks For Itself

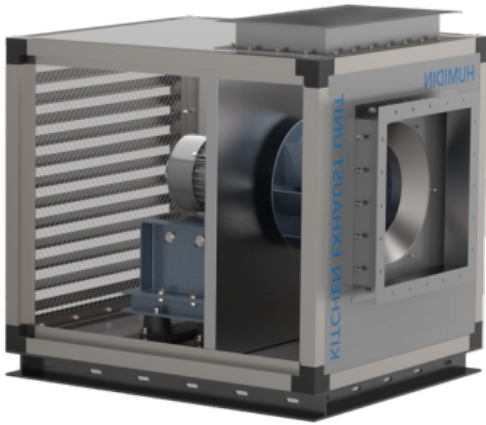

BIFURCATED FAN SECTION

HUMIDIN BIFURCATED FAN SECTION

THE BIFURCATED FAN SECTION Double Skin refers to an advanced design of the fan compartment in industrial ventilation and air handling systems, particularly in systems like air handling units (AHUS), HVAC systems, or pollution control equipment such as wet or dry scrubbers. The double-skin construction of the fan section involves the use of two layers of materials (often metal or composite materials) in the fan housing or enclosure. These layers provide additional insulation, protection, and durability, significantly enhancing the performance and longevity of the system.

FEATURES:

1. Enhanced Insulation and Thermal Protection:

The primary feature of a double-skin fan section is the additional insulation between the two layers. This insulation helps reduce heat transfer, keeping the internal components at a more stable temperature. This is particularly useful in systems that handle hot gases or environments where temperature fluctuations could affect system performance. The insulation also reduces the amount of heat lost, improving energy efficiency.

2. Noise Reduction

A double-skin fan section is designed to reduce operational noise. The two layers of material, especially if they are combined with soundproofing insulation, help absorb and dampen the vibrations and noise generated by the fan. This feature is especially beneficial in applications where noise levels need to be minimized for worker safety or environmental reasons, such as in HVAC systems in commercial or residential buildings, or in industrial processes where noise pollution could be an issue.

3. Increased Durability and Corrosion Resistance:

The double-skin design improves the fan section's ability to withstand corrosive environments. The outer layer of the fan section is usually made of corrosion-resistant materials (e.g., stainless steel or coated metals), providing additional protection for the fan and other internal components. This is particularly important in environments with high humidity, aggressive chemicals, or high salt concentrations, such as marine industries or chemical processing plants.

4. Prevention of Condensation:

The insulation layer between the skins prevents the formation of condensation inside the fan section. Condensation can cause corrosion or damage to electrical components and other parts of the fan system, especially in humid environments. The double-skin construction mitigates this risk, making the system more reliable in temperature-variable

5. Increased Structural Strength and Durability

The double-skin design improves the mechanical strength and rigidity of the fan enclosure. It helps the fan section withstand internal pressure, vibration, and external impacts, resulting in longer service life and improved operational reliability.

6. Improved Safety for Operators and Equipment

The outer protective skin acts as a safety barrier, shielding personnel from hot surfaces, moving components, and electrical parts. This enhances workplace safety and reduces the risk of accidental contact or injury during operation and maintenance.

7. Easy Maintenance and Service Access

The fan section can be designed with access doors and inspection panels on the outer skin, allowing easy servicing, cleaning, and inspection of internal components. This reduces maintenance time and system downtime, improving overall operational efficiency.

8. Flexible Design for Single Skin and Double Skin Applications

The fan section can be configured as single skin or double skin based on application requirements, cost considerations, and environmental conditions. This flexibility allows the system to be customized for HVAC units, AHUs, wet scrubbers, dry scrubbers, and other pollution control equipment.

9. Improved Energy Efficiency and System Performance

The double-skin fan section helps maintain consistent internal operating conditions by reducing heat loss and air leakage. This improves overall system efficiency, reduces load on the fan and motor, and contributes to lower energy consumption while ensuring stable and reliable performance over long-term operation.

APPLICATIONS

HVAC Systems:

- In commercial and industrial buildings, HVAC systems use double-skin fan sections to improve energy efficiency, reduce noise, and extend the life of the system. The insulation and corrosion resistance are particularly beneficial in maintaining the system's performance in diverse environments, from office buildings to hospitals or factories.
- **Industrial Ventilation Systems:**
Double-skin fan sections are commonly used in heavy-duty industrial applications like power plants, chemical manufacturing, and metal processing. These environments often require fans that can withstand harsh temperatures, corrosive gases, or other challenging conditions. The double-skin design offers increased protection for these critical components.
- **Air Handling Units (AHUs):**
Air handling units with double-skin fan sections are widely used in buildings that require large volumes of conditioned air, such as in data centers, shopping malls, and public buildings. The added insulation reduces energy loss, while the durability of the double-skin construction ensures that the AHU can perform over extended periods without significant degradation.

- **Scrubbers and Filtration Systems:**
In scrubbers and filtration systems used for air or gas cleaning, the fan section is a crucial component. The double-skin design helps these systems handle high temperatures and corrosive gases effectively, which is common in waste-to-energy plants, chemical industries, or metal smelting facilities.
- **Marine and Offshore Applications:**
In the marine industry and offshore facilities, the fan section double-skin design is ideal due to its resistance to corrosion from saltwater and harsh environmental conditions. The enhanced protection ensures that the fan systems continue to function optimally despite exposure to challenging weather and corrosive elements.
- **Energy Systems:**
Energy systems that handle hot exhaust gases, such as power generation plants, use double-skin fan sections to improve thermal insulation, prevent corrosion, and enhance performance in high-temperature environments. The double skin also contributes to higher energy efficiency, which is essential in energy-intensive applications.
- **Pharmaceutical and Clean Room Facilities**
Double-skin fan sections are used in pharmaceutical manufacturing units, laboratories, and clean rooms where strict control of air quality, temperature, and noise levels is required. The insulated and sealed construction helps maintain hygienic conditions, prevents contamination, and ensures reliable long-term operation.
- **Food Processing and Cold Storage Facilities**
In food processing plants and cold storage applications, double-skin fan sections help maintain stable temperatures and prevent condensation. The corrosion-resistant construction and insulation ensure hygienic operation, energy efficiency, and protection of equipment in moisture-prone environments.

DIMENSIONS TABLE OF BIFURCATED FAN SECTION

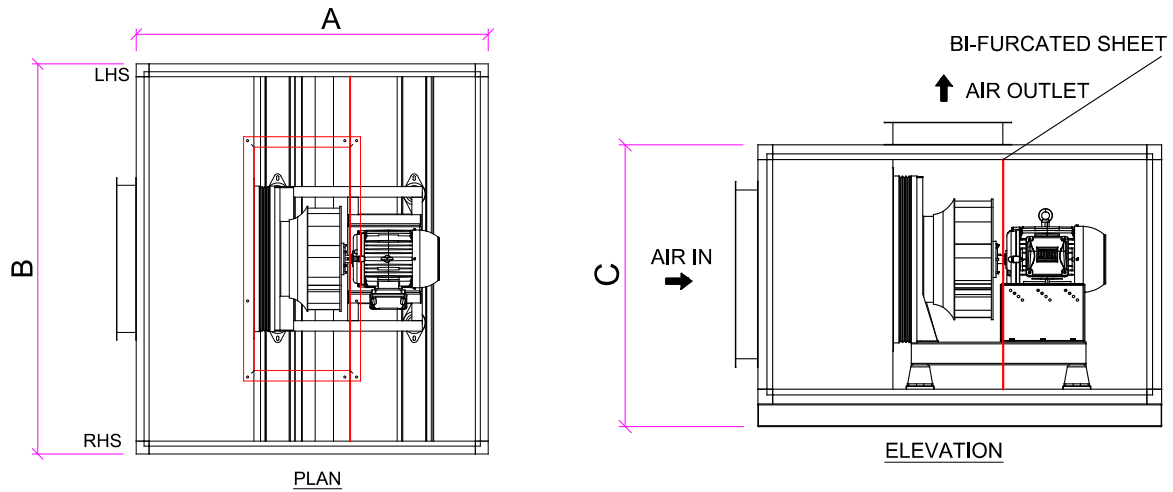

BIFURCATED FAN SECTION											
Air Volume (CFM)	Static Pressure (mmwg)	Fan Type	Outlet Vel. (m/s)	Fan Dia (mm)	Motor (HP)	Total Efficiency (%)	dB at 3mtr	RPM	A (mm)	B (mm)	C (mm)
1000	40	PLUG FAN	5.41	315	0.5	62	56	1865	1270	820	785
	50	PLUG FAN	5.41	315	1	60	58	2057	1270	820	785
	60	PLUG FAN	5.41	315	1	56	60	2219	1270	820	785
	70	PLUG FAN	5.41	315	1	54	62	2388	1270	820	785
2000	80	PLUG FAN	5.41	315	1.5	53	63	2537	1270	820	785
	40	PLUG FAN	8.51	355	1	69	63	1888	1405	1190	900
	50	PLUG FAN	8.51	355	1.5	69	64	2012	1405	1190	900
	60	PLUG FAN	8.51	355	1.5	69	65	2134	1405	1190	900
3000	70	PLUG FAN	8.51	355	2	68	67	2253	1405	1190	900
	80	PLUG FAN	8.51	355	2	66	68	2369	1405	1190	900
	40	PLUG FAN	10	400	1.5	68	65	1834	1430	1485	935
	50	PLUG FAN	10	400	2	70	65	1928	1430	1485	935
4000	60	PLUG FAN	10	400	3	71	66	2019	1430	1485	935
	70	PLUG FAN	10	400	3	71	67	2108	1430	1485	935
	80	PLUG FAN	10	400	3	71	68	2195	1430	1485	935
	40	PLUG FAN	10.6	450	2	66	64	1677	1500	1310	1205
5000	50	PLUG FAN	10.6	450	3	69	64	1750	1500	1310	1205
	60	PLUG FAN	10.6	450	3	71	65	1822	1500	1310	1205
	70	PLUG FAN	10.6	450	3	73	66	1892	1500	1310	1205
	80	PLUG FAN	10.6	450	5	74	68	1964	1500	1310	1205
6000	40	PLUG FAN	10.7	500	3	65	68	1522	1555	1485	1225
	50	PLUG FAN	10.7	500	3	68	68	1587	1555	1485	1225
	60	PLUG FAN	10.7	500	5	71	68	1651	1555	1485	1225
	70	PLUG FAN	10.7	500	5	72	69	1714	1555	1485	1225
7000	80	PLUG FAN	10.7	500	5	73	71	1778	1555	1485	1225
	40	PLUG FAN	10.2	560	3	70	74	1312	1640	1485	1515
	50	PLUG FAN	10.2	560	3	73	75	1377	1640	1485	1515
	60	PLUG FAN	10.2	560	5	74	76	1442	1640	1485	1515
8000	70	PLUG FAN	10.2	560	5	74	77	1506	1640	1485	1515
	80	PLUG FAN	10.2	560	5	74	77	1569	1640	1485	1515
	40	PLUG FAN	9.47	630	3	75	71	1117	1640	1775	1510
	50	PLUG FAN	9.47	630	5	75	72	1183	1640	1775	1510
9000	60	PLUG FAN	9.47	630	5	75	73	1247	1640	1775	1510
	70	PLUG FAN	9.47	630	5	74	74	1308	1640	1775	1510
	80	PLUG FAN	9.47	630	7.5	73	75	1367	1640	1775	1510
	40	PLUG FAN	8.5	710	5	75	72	943	1830	2070	1510
10000	50	PLUG FAN	8.5	710	5	75	73	1006	1830	2070	1510
	60	PLUG FAN	8.5	710	5	73	75	1066	1830	2070	1510
	70	PLUG FAN	8.5	710	7.5	70	76	1123	1830	2070	1510
	80	PLUG FAN	8.5	710	7.5	71	77	1180	1830	2070	1510
12000	40	PLUG FAN	9.6	710	5	75	74	999	1830	2070	1510
	50	PLUG FAN	9.6	710	5	75	75	1056	1830	2070	1510
	60	PLUG FAN	9.6	710	7.5	75	76	1113	1830	2070	1510
	70	PLUG FAN	9.6	710	7.5	74	77	1166	1830	2070	1510
80	PLUG FAN	9.6	710	7.5	73	78	1218	1830	2070	1510	

NOTE: ALL TECHNICAL & DIMENSIONS ARE ONLY FOR REFERENCE

DIMENSIONS TABLE OF BIFURCATED FAN SECTION

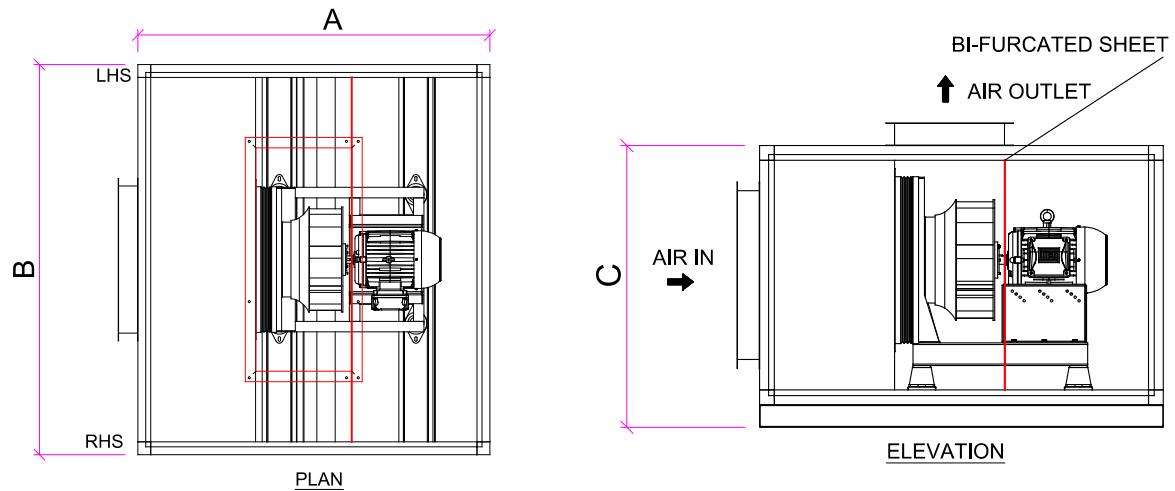

BIFURCATED FAN SECTION											
Air Volume (CFM)	Static Pressure (mmwg)	Fan Type	Outlet Vel. (m/s)	Fan Dia (mm)	Motor (HP)	Total Efficiency (%)	dB at 3mtr	RPM	A (mm)	B (mm)	C (mm)
10000	40	PLUG FAN	10.6	710	5	73	76	1060	1830	2070	1510
	50	PLUG FAN	10.6	710	7.5	75	77	1112	1830	2070	1510
	60	PLUG FAN	10.6	710	7.5	75	77	1164	1830	2070	1510
	70	PLUG FAN	10.6	710	7.5	75	78	1215	1830	2070	1510
	80	PLUG FAN	10.6	710	10	75	79	1264	1830	2070	1510
12000	40	PLUG FAN	10	800	7.5	74	76	912	1900	2140	1810
	50	PLUG FAN	10	800	7.5	75	77	960	1900	2140	1810
	60	PLUG FAN	10	800	7.5	75	77	1009	1900	2140	1810
	70	PLUG FAN	10	800	10	75	78	1055	1900	2140	1810
	80	PLUG FAN	10	800	10	74	79	1100	1900	2140	1810
16000	40	PLUG FAN	10.6	900	7.5	72	69	817	2100	2190	2125
	50	PLUG FAN	10.6	900	10	73	69	857	2100	2190	2125
	60	PLUG FAN	10.6	900	10	74	70	897	2100	2190	2125
	70	PLUG FAN	10.6	900	15	75	71	936	2100	2190	2125
	80	PLUG FAN	10.6	900	15	75	72	975	2100	2190	2125
20000	40	PLUG FAN	10.7	1000	10	72	73	742	2150	3000	1805
	50	PLUG FAN	10.7	1000	15	73	73	778	2150	3000	1805
	60	PLUG FAN	10.7	1000	15	74	74	813	2150	3000	1805
	70	PLUG FAN	10.7	1000	15	75	74	848	2150	3000	1805
	80	PLUG FAN	10.7	1000	20	75	75	882	2150	3000	1805
24000	40	PLUG FAN	10.3	1120	15	72	73	646	2310	3450	2125
	50	PLUG FAN	10.3	1120	15	74	73	680	2310	3450	2125
	60	PLUG FAN	10.3	1120	15	75	74	712	2310	3450	2125
	70	PLUG FAN	10.3	1120	20	75	74	745	2310	3450	2125
	80	PLUG FAN	10.3	1120	20	75	75	777	2310	3450	2125
30000	40	PLUG FAN	12.8	1120	20	69	78	745	2310	3450	2125
	50	PLUG FAN	12.8	1120	20	71	78	772	2310	3450	2125
	60	PLUG FAN	12.8	1120	20	72	78	799	2310	3450	2125
	70	PLUG FAN	12.8	1120	25	73	78	826	2310	3450	2125
	80	PLUG FAN	12.8	1120	25	74	78	852	2310	3450	2125

NOTE: ALL TECHNICAL & DIMENSIONS ARE ONLY FOR REFERENCE

HUMIDIN

Sales & Marketing Department

North India: (Ventilation Dept.)
Phone: +91-9654400710
Email Id: tc@humidin.com

East India: (Ventilation Dept.)
Phone: +91-9654551093
Email Id: tceast@humidin.com

West India: (Ventilation Dept.)
Phone: +91-9654551015
Email id: tcwest@humidin.com

South India: (Ventilation Dept.)
Phone: +91-9654781452
Email Id: tcsouth@humidin.com

All India: (Air Handling Unit Dept.)
Phone: +91-9654557807
Email Id: ahu@humidin.com

After Sales Service Department (24x7)
Phone: +91-9654452926
Email Id: service@humidin.com

COUNTRIES:

RIYADH:

Email Id: riyadh@humidin.com

EGYPT:

Email Id: egypt@humidin.com



HR Department

Phone: +91-7290065533

Email Id: hr@humidin.com

hrmanager@humidin.com

Finance Department

Phone: +91-9654452925

Email Id: accounts@humidin.com

The intention of this brochure is to introduce you to, and acquaint you with the capabilities of the HUMIDIN organization in the offered product areas. It will not answer all your immediate questions, and indeed, it will no doubt raise others. We welcome your interest in our products and shall be very pleased to provide further information.

GUARANTEES

HUMIDIN guarantees its products to be free of defects in materials and workmanship for a period of one year from the date of delivery from the factory, provided motors are properly installed with overload protector. Humidin agrees to repair or replace defective parts or part to be returned to the factory, all transportation charges prepaid. Humidin does not guarantee against abrasion, corrosion or erosion. Humidin shall not be held responsible for any charges in connection with the removal or replacement of alleged defective equipment nor for incidental consequential damages

A.C HUMIDIN AIR SYSTEMS PVT.LTD.

Plot C18, Tronica City Industrial Area
Loni Dist. -201102